

FREEZER | Countertop Freezers

UPRIGHT FREEZER



RNG 50

CUSTOMIZATION AVAILABLE
PERSONALIZZAZIONE DISPONIBILE



DETAILS



Lock fitted as standard



Painted aluminium door frame with integrated handle

GENERAL FEATURES

50 Lt. Upright freezer	•
White coated steel for internal and external side	•
Static Cooling	•
Manual Defrost	•
Foaming Agent Cyclopentane (60mm per side)	•
Removable Gasket	•
Interior LED light	•
Triple heated safety tempered glass	•
Self Closing Door	•
Painted aluminium door frame with integrated handle	•
Lock fitted as standard	•
Adjustable shelves: 2 Pcs	•
N.4 Adjustable feet	•
Energy efficiency class: C	•

TECHNICAL SPECIFICATIONS

Capacity	50 L
Temperature	L2 (-12°C--18°C)
Consumption	2.53 kWh/24h
Rated Power	156 W
Noise level	45 dB(A)
Net Weight	40 Kg
Gross Weight	45 Kg
External Dimensions (WxDxH mm)	570x535x530
Internal Dimensions (WxDxH mm)	450x420x380
Packaging dimensions (WxDxH mm)	610x580x580
Loading quantities 20'/40'/40'HQ	144/304/304

CERTIFICATION

CE  RoHS

PRODUCT DIMENSIONS

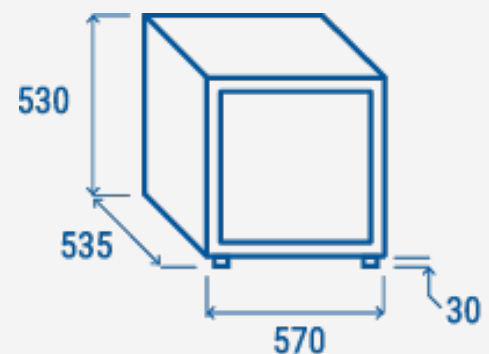

COOL HEAD EUROPE 
We make the world a cooler place

www.coolheadeurope.com